

UCHW-H18AF2
UCHW-H18CF2



HIGH WALL SPLIT AIR CONDITIONER

● **User manual/Installation Manual**

Air conditioners are units that should have the professional technicians do the installation for you. This Instruction Manual is the universal-purpose version for the models of split wall-mounted air conditioners manufactured by our Co. The appearance of the units that you purchase might be slightly different from the ones described in the Manual, but it does not affect your proper operations and usage. Please read carefully the sections corresponding to the specific model you choose, and keep the Manual properly so as to facilitate your reference at later time.

Addition to the user manual:

The appliance is not intended for use by young children or infirm persons without supervision; Young children should be supervised to ensure that they do not play with the appliance.

Contents

Instructions to users	1
The name of each part and its function	3
Operation and indication sections of remote controller	4
Use of remote controller	5
Features of heating operations	6
Methods of maintenance	7
Treatment at service call	8
We hope you will know the following when using the unit	9
Installation of electric components	10

Please read the "Instruction Manual" carefully prior to the use of your air conditioner so as to ensure proper operations.

Instructions for Installation

- Make sure to have the professional after-sale service persons of our company or the authorized dealers to install the units before you use.

1. The units are not to be installed at places where there might be leakage of combustible gases.



In case that the leaked gas accumulates around the units, there might occur the accident of fire hazards.

Make sure that the earth leakage-circuit breaker is installed.

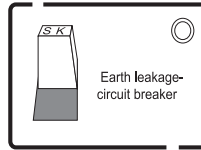

Absence of the earth leakage-circuit breaker might lead to electric shock and some other hazards.

After the connecting of the wires between the indoor unit and the outdoor unit, check whether the connecting is loose or not by pulling the wire with a little force.

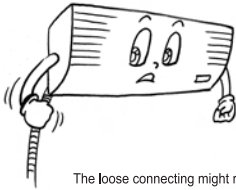

The loose connecting might result in fire hazard.

Make sure that the air conditioner is properly grounded.

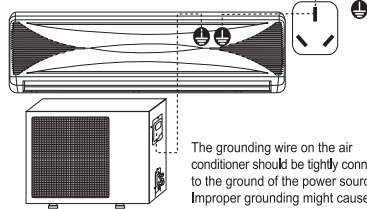

The grounding wire on the air conditioner should be tightly connected to the ground of the power source. Improper grounding might cause electric shocks or other hazards.

Instructions for Operation

Never try to stop the operation of the air conditioner by operate the switch.

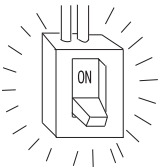

Such performance might cause electric shocks or fire hazards.

Do not press, stretch, damage, heat or modify the power line.

It might cause electric shocks, overheating, fire hazards, etc. If the power line wire is damaged or needs to be replaced due to some other reasons, please make sure to have dealer or the authorized maintenance people to do the replacement.

Do not operate the switch by wet hands.

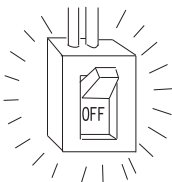

It might cause electric shocks.

Never use the fuse with incorrect capacity or any other metal wires.

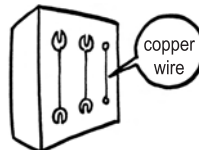

The use of metal or copper wires for fuse might cause operational failures or fire hazards.

USER'S MANUAL

Split Wall-Mounted Air Conditioner

Try to avoid the sunlight and hot air from entering the room.

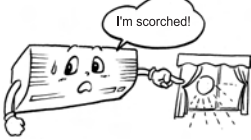

During the cooling operation, curtains or window-blinds should be used to shade off the sunlight.

Try to minimize the generation of heat during the operation of cooling.



Place the heating sources out of the room.

Do not use combusting apparatuses in the air-conditioned room.



It might lead to the incomplete combustion of these apparatuses.

Do not place insecticides or paints and other flammable sprays near the air conditioner, or spray them directly at the air conditioner.



It might cause fire hazards.

When it is necessary to use the air conditioner and the combusting apparatuses in the same room, air ventilation has to be made from time to time.

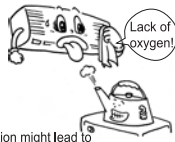

Insufficient ventilation might lead to lack of oxygen or some other dangers.

Prior to the maintenance of the air conditioner, please cut off the power supply first. Never do the cleaning of the units when the fan is in high-speed operations.



Do not insert sticks or bars into the air vents.



As the fan is in high-speed operation, the insertion might lead to accidents.

Adjust the air direction correctly.



Properly adjust the up/down and left/right directions of the air flow so as to get the even room temperature.

Do not keep exposed to the cool air for long time.



It might cause discomforts of the body, which is harmful to your health.

Do not clean the air conditioner with water.



It might cause electric shocks.

Do not attach, hang or stack articles on the air conditioner.



It might lead to the falling down of the air conditioner unit, which will result in accidents or injuries.

Check the supporting structures of the units carefully.



In case of damages, the supporting structures should be immediately repaired so as to avoid falling down of the unit, which might cause human injuries or other accidents.

Do not sit on the outdoor unit or place any other objects on it.



The falling down of the unit or the objects might cause human injuries and other accidents.

Do not use the following substances:



Hot water (over 40°C or 104°F)
The use of hot water will deform the air conditioner or make it fade in color.
Gasoline, paint diluent, benzene and polishing agents, etc.
These substances will deform the air conditioner or cause scratches.

Put down the power when the unit is not in use for long time so as to ensure safety.



When the plug is to be pulled out, make sure that the switch of the air conditioner is turned off.

Instructions for Removal and Repair

- When removal or repair is needed, please contact the dealer or authorized maintenance & installation people.
- In case of any abnormal occurrences (smell of burning), please stop the operation at once, cut off the power supply and contact the dealer or authorized maintenance people.

【The name of each part and its function】

There are many models, features and appearance will vary, all the figures provide a demonstration to introduce the function.

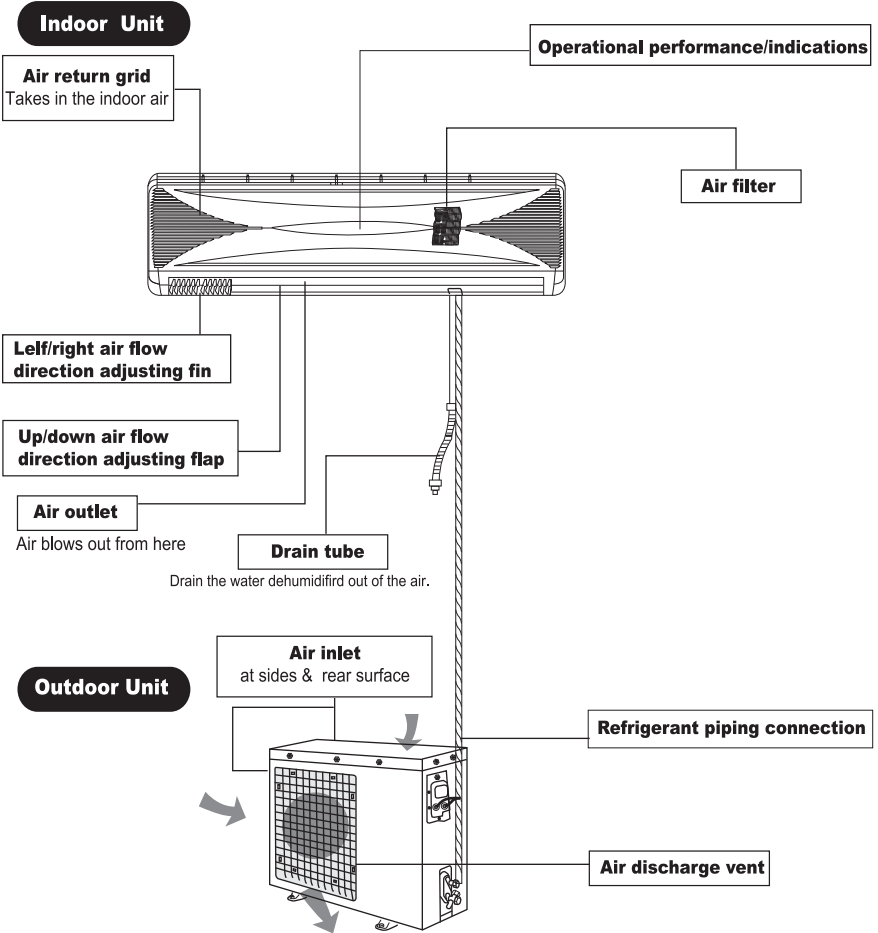

Unit operation section

How to open

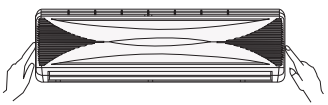

Lightly push both sides of the air inlet grid at the bottom and pull it to this side till a resistance is felt.

How to close

Push down the air inlet grid and the push both sides of air inlet grid at the bottom.

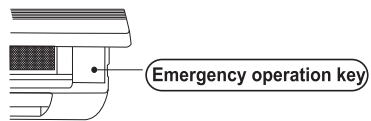

This button can be used as an emergency measure to turn on/off unit when remote controller is not available.

Note: Do not open the grid at an angle over 60 degrees. Do not operate the units with too much force.

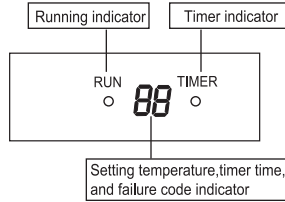

【Operation and indication sections of remote controller】

This remote controller is the general one of our company, it can be used for many types of our air-conditioners. We beg your forgiveness that we would not introduce the button or indicator which is not applicable for the units you purchased.

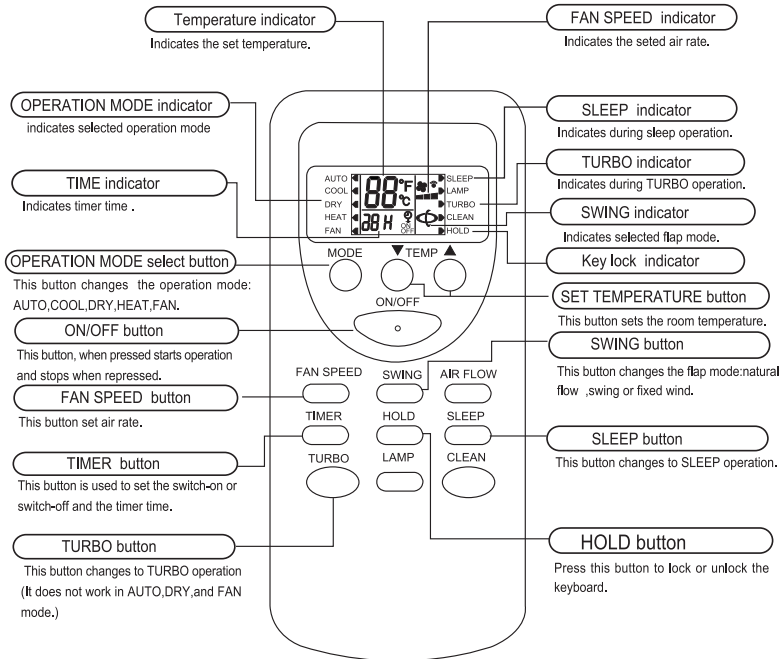

NOTE:

Above figure shows all indications for the purpose of explanation, but practically only the pertinent parts are indicated. When air-conditioner is cooling-only model, the HEAT is for FAN.

Transmission procedure

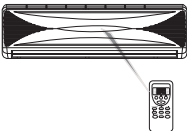

When each button on the remote controller is pressed with the remote controller pointing toward the air conditioner unit, signal is sent. When the signal is received correctly, the receiving sound is emitted from the unit.

OPERATING MACHINE IN SELECTED MODES

1. Point the remote controller at the unit, press the ON/OFF button, then press the MODE button, select the needed mode: ATUO, COOL, DRY, HEAT, or FAN.
2. Press the SET TEMPERATURE button to increase or decrease the readings until the needed temperature is displayed. The room set temperature range is from 16°C-32°C (61°F-90°F).
(It would be automatically set at 25°C (76°F) and unadjustable in AUTO and DRY mode.)
3. Press the FAN SPEED button to choose the air rate you want: Low (display indicates "■"), Med (display indicates "■■"), Hi (display indicates "■■■"), Auto (display "■■■■" indicator flashing).
(It would be automatically set at low speed and unadjustable in DRY mode.)
4. Press the SWING button to choose the up/down air flow direction you want: natural flow (display indicates "↕"), swing (display "↔" indicator flashing), fixed wind (display indicates "↻").
(It would be automatically set at fixed wind air flow direction in DRY mode.)

TURBO OPERATION

Press TURBO button during COOL or HEAT operation, the air rate can be set in HIGH. Press the TURBO button again can release the TURBO operation.

Note: during TURBO operation, the air rate can't be changed.

ADJUSTING LEFT/RIGHT AIR FLOW DIRECTION

Adjust the direction by moving directly the left/right air flow direction adjusting fin by hand.

Caution: when adjust the direction, stop air conditioner.

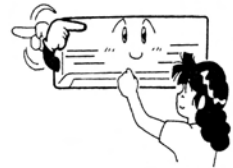

TIMER OPERATION

Set turning off time

Set the time for the unit to turn off and when it is time, the air conditioner will automatically stop operating.

1. During the operation of the air conditioner, press the TIMER button and the air conditioner will enter the timed switch-off mode.
2. Continually press the TIMER button to set the needed time for switching off the machine. The timer can make the setting in the range from 1-24 hours. Every the button is pressed, indication change is the following sequence: 1 → 2 → → 24 → cancel (no indication) → 1.
3. After the setting of the timed switch-off, the digits shown on the display screen will go down by 1 for every elapsed hour. The displayed digits indicate the remaining time prior to the timed switch-off.

Set turning on time

Set the time for the unit to turn on and when it is time, the air conditioner will automatically start operating.

1. When the air conditioner is in the standby mode, press the TIMER button and the air conditioner will enter the timed switch-on mode.
2. Continually press the TIMER button to set the needed time for switching on the machine. The timer can make the setting in the range from 1-24 hours. Every the button is pressed, indication change is the following sequence: 1 → 2 → → 24 → cancel (no indication) → 1.
3. After the setting of the timed switch-on, the digits shown on the display screen will go down by 1 for every elapsed hour. The displayed digits indicate the remaining time prior to the timed switch-on.

Releasing procedure

When the indication on display screen is 24 hour, press the TIMER button again to delete the timed mode.

SLEEP OPERATION

Use this mode to reduce operation sound when sleeping, etc.
Press the SLEEP button, the air flow sound from the indoor unit is decreased.
Press the SLEEP button again can release the mode.

NOTE:

- Use the sleep mode when you are going to bed. If this mode is used in the day, the capacity is reduced since the ambient temperature is too high. (COOL MODE).
- During the operation of cooling, the room temperature will be raised gradually by 2°C (36°F) higher than the setting after the machine begins to operate in the sleeping mode.
- During the operation of heating mode, the room temperature will be dropped gradually 5°C (41°F) lower than the setting after the machine begins to operate in the sleeping mode.

REPLACEMENT OF BATTERIES

- When the signal from the remote controller becomes weak and the indoor unit can not receive it properly; or the indications on the display screen becomes blurred, please slide the back cover and replace with two new batteries.
- The positive and negative poles must match the installation positions.
- New batteries of the same type have to be used for replacement.
- If the remote controller is not to be used for long time, take out the batteries so as to prevent the leakage of the electrolyte from damaging the controller.

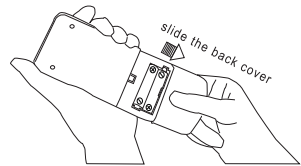

【Features of Heating Operations】

Basic principles and performances

- The machines absorb heat from the outdoor air and transfer it indoors so as to heat the room air. The heating capabilities through this principle of heat pump go up/down with the increase/decrease of the temperatures of the outdoor air.
- It only needs a fairly short time for such hot air circulation system to raise the room temperature.
- When the outdoor air temperature is very low, the system can be used together with other heating devices. But good ventilation should be maintained to ensure safety and prevent accidents.

Defrosting

When the outdoor air temperature is very low and humidity is very high, frosting will occur to the heat exchanger of the outdoor unit, which has negative impacts upon the efficiency of the heating performance. In such case, the automatic defrosting function will come into play. The heating operation will be stopped for 5-15 minutes to do the defrosting.

- The fans of both the outdoor and indoor units are stopped.
- During the defrosting, the outdoor unit might generate some steam. It is caused by fast defrosting, which is not a performance failure.
- Upon the completion of the defrosting process, the heating operation is resumed.

[Methods of Maintenance]

The air conditioner must be turned off power before the maintenance is to be carried out.

Before the season of operation

- 1** Check if there are any blocking materials in the intake and outlet vents of the indoor and outdoor units.

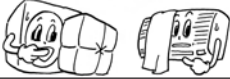

- 2** Check if the installation stand is corroded or rusty.

- 3** Check if the machine is properly grounded.



- 4** Check if the air filter is clean.

- 5** Connect to the power source.

- 6** Put batteries in the remote controller.

After the season of operation

- 1** Set the temperature at 30°C or 86°F and operate in the fan status for about half a day.



To make the interior of the units dry

- 2** Stop the operation of the machine and turn off the power switch.

The air conditioner will consume about 5W of electric power after the machine is turned off. For the purpose of energy saving and safety, it is advisable to pull the plug out during the non-operational seasons.



- 3** Clean and install the air filter screen.

- 4** Clean the indoor and outdoor units.



- 5** Take the batteries out from the remote controller.

During the season of operation

The cleaning of the air filter screen (Standard intervals should be once every two weeks).

- 1** Remove the air filter screen from the unit.

- Gently press the two lower ends of the grid and open it.
- Gently pull up the air filter screen and take it out in the direction of your body.

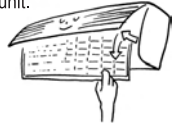

- 2** Clean the air filter screen.

if the screen is very dirty, please use lukewarm water (about 30°C or 86°F) to clean it. Air it dry after the cleaning.

Note:

- Do not use boiling water to clean the screen.
- Do not bake the screen dry over a fire.
- Do not exert too much force in pulling and stretching the screen.

- 3** Install the air filter screen.

To operate the air conditioner without the air filter screen on will cause the interior of the machine dirty which might lead to poor performances or damages to the units.

Clean the air conditioner

- Use a soft and dry cloth to rub the air conditioner, or use a vacuum cleaner to clean it.
- If the air conditioner is very dirty, use a piece of cloth and soak it with neutral home-use detergent to do the cleaning.





Note:



If the air filter screen is blocked by dust or dirt, the performance of cooling and heating will be affected, with the operation noise and power consumption increased. Therefore, the air filter screen should be cleaned regularly.

Please check the following before requesting after-sale service from your dealer .



The air conditioner does not operate at all .

<p>Is the power plug in an outlet ?</p> 	<p>Is the time set to "ON" position ?</p> 	<p>Is there a power failure or a blown fuse ?</p> 
---	---	---

Poor cooling or heating performance .





<p>Is the room temperature setting suitable ?</p> <p>suitable TEMP</p> 	<p>Are the air filters clean (Not clogged) ?</p> 	<p>Are the window (s) and door (s) opened ?</p> 
--	--	---

Poor cooling performance .

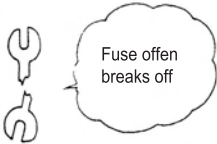
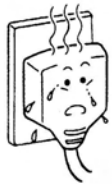
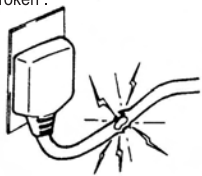
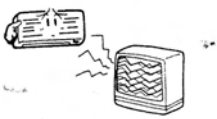

<p>Is direct sunlight entering the room ?</p> 	<p>Is there a heat source in the room ?</p> 	<p>Are there too many people in the room ?</p> 
---	---	--

Cases requiring immediate contact with the distributor

Pull out the power plug immediately and inform to your distributor in the following situations:

<p>Fuse or breaker often breaks off</p> 	<p>Power plug or code is excessively hot</p> 	<p>Covering of power plug or code is broken</p> 
<p>Malfunction is observed TV , radio or other devices .</p> 	<p>Switch dose not actuate surely</p> 	<p>Abnormal noise is heard during operation</p> 
<p>When faulty operation movement is observed when the RUN button is pressed , even after pulling out the power pulg and restarting the operation after 3 minutes , faulty movement does not disappear .</p> 		

[We hope you will know the following when using the unit]

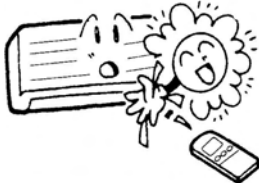
<p>The unit can not be restarted just after shut down . (RUN lamp is illuminating)</p> 	<p>Restart is stopped for 3 minutes after shut down to protect the unit .</p>  <p>Three-minute protection timer incorporated in the microcomputer actuates automatically . Except that power is connected , this function does not actuate .</p>
<p>Air is not blown out at starting of heating operation .</p>	<p>Air blow is stopped to prevent blowing out of cold air until the indoor heat exchanger is warmed . (2 to 5 min) (HOT KEEP)</p>
<p>Air is not blown out for 6 to 12 min , at heating operation .</p>	<p>When outdoor temperature is low and humidity is high , the unit sometimes performs defrosting automatically . Please wait . During defrosting , water or steam are raising from the outdoor unit .</p>
<p>Air is not blown out at DRY operation .</p>	<p>Indoor fan is sometimes stopped to prevent vapor of dehumidified moisture and save energy .</p>
<p>Mist is blown out at COOL operation .</p>	<p>This phenomenon sometimes occurs when the temperature and humidity of the room are very high , but it will disappear with the lowering of the temperature and humidity .</p>
<p>Odor is sent out .</p>	<p>Air blown out during operation may smell . This is the smell of tobacco or cosmetics stuck to the unit .</p>
<p>Noise is heard cracking sound .</p> 	<p>This is caused by the refrigerant that is circulating inside the unit .</p>
<p>Noise is heard cracking sound .After a power stoppage or after disconnecting the power supply plug.</p>	<p>This is caused by heat expansion or contraction of plastics.</p>
<p>Operation can not be restarted even if the power is recovered.</p>	<p>The memory circuit of the microcomputer is cleared . Operate the remote controller again to restart the operation .</p>
<p>Remote control signals are not received .</p>	<p>Remote control signals may not be received when signal receiver on the air conditioner body is exposed to direct sunlight or strong lighting . In that case , interrupt the sunlight or darken the lighting .</p> 
<p>Moisture may form on the air outlet grilles .</p>	<p>If the unit is operated for a long period of time with the high humidity , moisture may form on the air outlet grilles and drip down .</p>

Points of attention

- HACR type breaker should be utilized along with proper installation;
- Make sure of the applicable voltage and cables or wires for the specific model to be used, before doing the connections;
- Read the prompts at the terminal board for wiring. Make sure the wiring is done correctly.
- Pay attention to the poles of the signal terminal and connect the terminals to match the identification numbers.
- When the wiring connections are wrong, the compressor will not work.
- The connecting wires are not supplied.
- The provision for connection of one of the wiring systems that in accordance with the National Electric Code shall be had. ANSI/NFPA 70-1990 would be acceptable for it.
- The connecting wires specification is 14 AWG, VW-1 (or THHW), copper core and 90°C (or 194°F). Their set screw diameter is 4 mm. The power source is 115V, 60Hz and 1 phase. Minimum circuit ampacity of the wiring systems is 20A.

Connection of wires for outdoor unit

Method1 (Suitable for non-quick coupler)

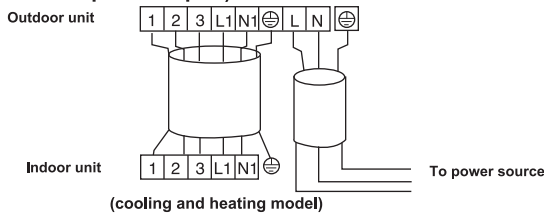

Method2 (Suitable for quick coupler)

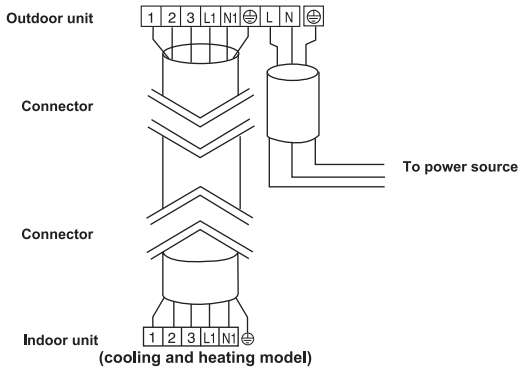

Note:

- The environment conditions must be taken into consideration when the connections of power cable are made (such as the ambient temperature, direct exposure to heat/direct exposure to sunlight);
- The specifications for the power cable refer to the minimum values of the metal core wires. Taking into consideration the voltage losses, the core wire of power cable must be one size larger than the specifications;
- The grounding wire must be connected to the indoor units and outdoor units;
- The laying of power cables must be done by qualified electricians and comply with the regulations of the local power supply authorities and with the standards of the electric appliances;

Caution:

If you purchase the cooling and heating model, you should connect the indoor wire connector with outdoor probe wire connector for defrosting, see below figure:

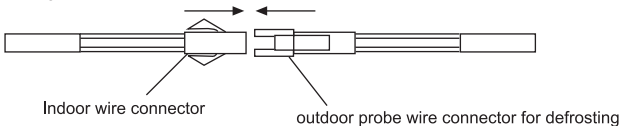

Foreword

Air conditioners are units that should have the professional technicians do the installation for you.

This Instruction Guide is the universal-purpose version for the models of split wall-mounted air conditioners manufactured by our Co. The appearance of the units that you purchase might be slightly different from the ones described in the Guide, but it does not affect your proper operations and usage.

Please read carefully the sections corresponding to the specific model you choose, and keep the Guide properly so as to facilitate your reference at later time.

CONTENTS

Selection of installation positions for indoor unit	1
Selection of installation positions for outdoor unit	2
Installation fixture of indoor unit	3
Installation fixture of outdoor unit	4
Pipelines connection	4
Air purging	6
Connection of power cable	7
Finishing touches and test running	7
Is the unit installed correctly?	7
Self diagnosis functions	8

*** Selection of installation positions for indoor unit***

- * To be installed at the position where the air delivered from the unit can reach every corner of the room;
- * To avoid being affected by the outdoor air;
- * To avoid blockage to the air inlet or outlet of the unit;
- * To avoid too much oil smoke or steam;
- * To avoid possible generation, inflow, lingering or leakage of flammable gases;
- * To avoid high-frequency facilities (such as high frequency arc welders, etc.);
- * To avoid the places where acid solutions are frequently used;
- * To avoid the places where some special sprayers (sulfides) are frequently used.
- * Not to install a fire alarming device near the air outlet of the unit (during operation, the fire alarm device might be erroneously triggered by the warm air from the unit);

*** Make sure of enough space for installation and maintenance.***

- * To take into consideration the operational convenience and safety in installation, it is recommended to ensure enough space between the unit and the walls.

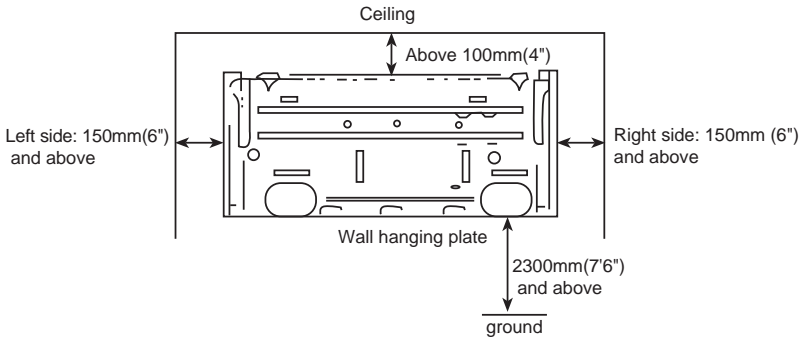

*** Height limits of indoor and outdoor units.***

- * Either the indoor unit or the outdoor unit can be higher, but the height difference must comply with the stated requirements.
- * Try to reduce the bending of the piping line as much as possible so as to avoid possible negative impacts upon the performances of the units.

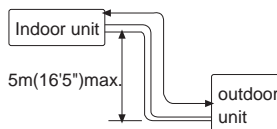

Selection of installation positions for outdoor unit

- * To install the outdoor unit at the places which can stand the load of the machine weight and will not cause big vibrations and noises;
- * To install the unit at the places not to be exposed to rain or direct sunshine, and the places with good ventilation;
- * The noises generated from the unit will not affect the neighboring places;
- * Do not install the unit on non-metal frame;
- * Not to install the unit at the places where there might occur the generation, inflow, stay or leakage of inflammable gases;
- * Pay attention to the drainage of the condensed water from the base plate during operations;
- * To avoid the air outlet being directly against the wind.

Detailed space requirements around the outdoor unit

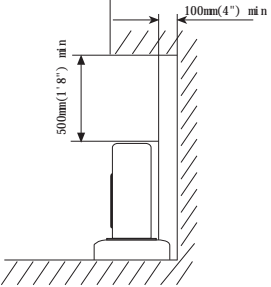
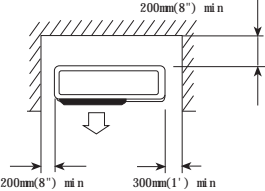
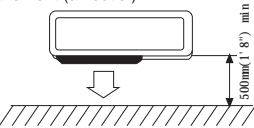
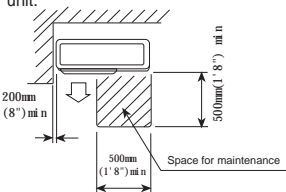
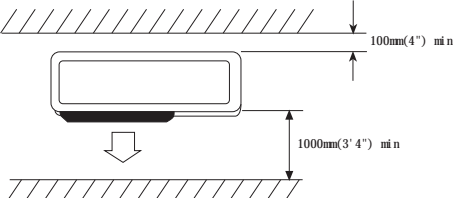
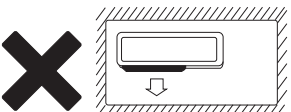
<p>1. When there are obstacles above the unit</p> 	<p>2. When the front (air outlet) is open</p> 	<p>3. When there are obstacles only in the front (air outlet)</p>  <p>Space for maintenance Shown as in the following figure. Keep the maintenance space in front of the unit.</p> 
<p>4. When there are obstacles at the front and rear sides.</p> 		<p>5. When there are obstacles all around the unit on four sides. Although the top side is open, the installation is not to be done if there are obstacles all around.</p>  <p>* At least two sides should be kept open.</p>

Installation fixture of indoor unit

Pipelines can be connected in the directions of****
****and* as indicated in Fig.1. When the pipelines
are connected to the directions of***and*, a groove
for the pipes has to be opened at the proper place on
the base stand.

Fig.1

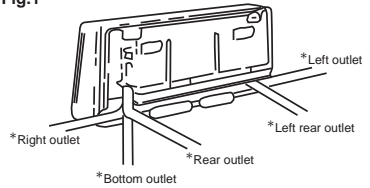

1.Installation of wall-mounting plate

Fix the wall-mounting plate firmly on the wall with screws.
Make sure of the leveling of the plate. Slanted wall-mounting
plate might jeopardize the smooth discharge of the condensed
water.

2.Drill holes on the wall

Drill holes at places slightly below the wall-mounting plate,
with hole diameter of 65mm(2-3/5") and the outer edge of
the hole 5-10mm(1/5-2/5") lower (Fig.2) so that the condensed
water can smoothly flow out. Cut the wall penetrating pipe
to proper length according to the thickness of the wall (3-
5mm(1/10-1/5") longer than the wall thickness) and insert
the pipe as indicated in Fig.2.

Fig.2

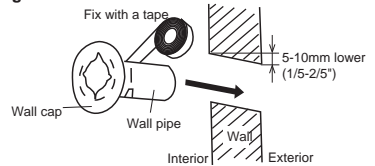

3.Installation of drain pipe

Install the pipelines of the indoor unit in accordance with
the direction of the wall holes. Wrap tightly the drain pipe
and the pipelines with tape. Make sure that the drain pipe
is underneath the pipelines. (Fig.3) (When the drain pipe
passes the room interior, some condensed water might
occur to its surfaces if the humidity is very high).

Fig.3

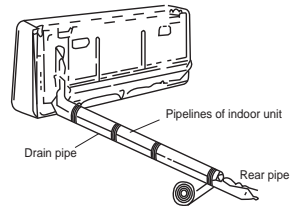

4.Installation of indoor unit

Pass the connection wires, connecting pipelines and drain
pipe through the wall hole. Hang the indoor unit on the
hooks at the top of the wall-mounting plate so that the
hooks at the bottom of the indoor unit match the hooks of
the wall-mounting plate. (Fig.4)

Fig.4

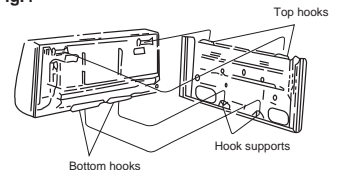

Inspections:

- a. Check if the hooks at the top and bottom are firmly fixed.
- b. Check if the position of the master unit is properly leveled.
- c. The drain pipe should not curve upward (Fig.5).
- d. The drain pipe should be at the lower part of the wall pipes (Fig. 5).

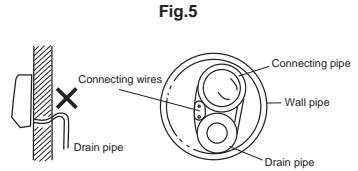

*** Installation fixture of outdoor unit ***

- * Try to ship the product to the installation location in its original package;
- * As the gravity center of the unit is not at the installation center, special caution should be taken when using hoisting cables to lift it up;
- * During shipping, the outdoor unit must not be slanted to over 45 degrees (Do not store the unit in a horizontal way).
- * Use expansion bolts to fix the mounting supports on the wall;
- * Use bolts and nuts to fix the outdoor unit firmly on the supports and keep on the same level;
- * If the unit is installed on the wall or at the rooftop, the supports have to be firmly fixed so as to resist earthquake or strong wind.

Dimensions for parallel units installations

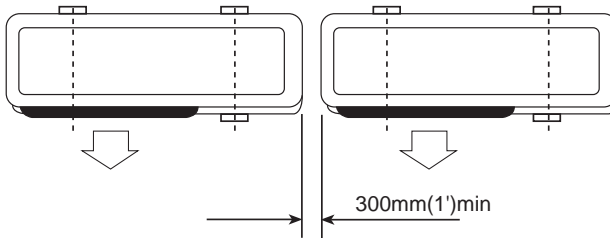

*** Pipelines connection ***

*** Ordinary pipelines connection** (it is suitable for non-quick coupler)

No dust, foreign articles, air or moisture should be allowed to enter the air conditioning system. Careful attention should be paid when pipeline connection for outdoor unit is made. Try to avoid repeated curves as much as possible, otherwise hardening or cracks might be caused to the copper pipes. Suitable wrenches should be used when the pipeline connection is done so as to ensure appropriate torque (refer to following torque Table 1). Excessive torque might damage the joints while too little torque might lead to leakage.

Table 1 Torque based upon the wrench to be used

Outer diameter of copper pipe	Tightening torque	Strengthened tightening torque
∅ 6.35(1/4")	160kgf.cm(63kgf.inch)	200kgf.cm(79kgf.inch)
∅ 9.52(3/8")	300kgf.cm(118kgf.inch)	350kgf.cm(138kgf.inch)
∅ 12.7(1/2")	500kgf.cm(197kgf.inch)	550kgf.cm(216kgf.inch)
∅ 15.88(5/8")	750kgf.cm(295kgf.inch)	800kgf.cm(315kgf.inch)
∅ 19.05(3/4")	1200kgf.cm(472kgf.inch)	1400kgf.cm(551kgf.inch)

*** Special pipelines connection**(it is suitable for quick coupler)

In case of the users purchasing the machine for quick coupler, there is no need to do the air purging procedures and the following pipeline connection procedures should be adopted:

- 1.Remove the dust caps from the indoor and outdoor units, and the connecting pipe.
- 2.Align the joint counter of connecting pipe with the proper indoor and outdoor joint conic surfaces,tighten the connecting nut manually.Then,make it secure with a wrench as shown Fig. 6 ,applying to above torque Table 1.
- 3.Remove the two valve core caps from the outdoor unit.
- 4.Turn on the high and low pressure valve cores with an socket wrench,then tighten the two valve core caps of the outdoor unit (Fig.7).
- 5.Finally ,wrap the hot insulating cotton around the joints of indoor and outdoor units.

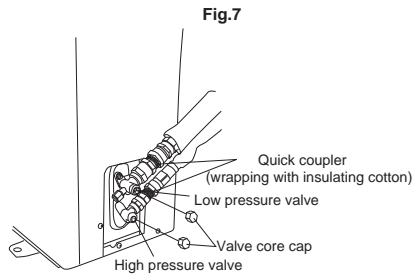
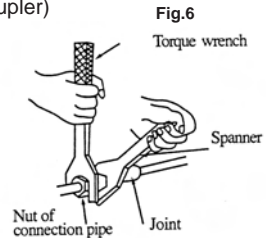

*** Notes on installation of quick coupler:**

- 1.Connecting pipe bending minimum radius parameters (Table 2)
- 2.Quick coupler assembly and disassembly limit: the assembly and disassembly times are inadvisably more than 7.

Table 2 Minimum bending radius

Normal diameter(mm)	Minimum bending radius(mm)	cooling capacity
DN8(5/16")	80(3")	2100~2300W (7000~8000BTU)
DN10-12 (1/2")	100(4")	2500~5100W (9000~18000BTU)
DN14-16 (5/8")	150(6")	6100~7000W (22000~24000BTU)

* Air purging*

* Air purging with vacuum pump

1. Check that pipelines connection have been properly connected, remove the charging port cap, and connect the manifold gauge and the vacuum pump to the charging valve by service hoses as shown Fig.8.

2. Open the valve of the low pressure side of manifold gauge, then, run the vacuum pump. Vacuum the indoor unit and the connecting pipes until the pressure in them lowers to below 1.5mmHG (The operation time for vacuuming is about 10 minutes). When the desired vacuum is reached, close the valve of the low pressure of the manifold and stop the vacuum pump.

3. Disconnect the service hoses and fit the cap to the charging valve.

4. Remove the blank caps, and fully open the spindles of the 2-way and 3-ways valves with a service valve wrench.

5. Tighten the blank caps of the 2-way and 3-ways valves, applying the above torque Table 1.

* Adding refrigerant

Refrigerant must be added if the piping measures more than 5 metres (16'5") in length. This operation can only be performed by a professional technician, for the additional amount, see the table 3 below.

Table 3

Additional refrigerant amount	
Liquid pipe diameter $\varnothing 6.35(1/4")$	Liquid pipe diameter: $\varnothing 9.52(3/8")$
(piping length-5)m x 30g or (piping length-16)ft x 0.3oz	(piping length-5)m x 65g or (piping length-16)ft x 0.7oz

* Gas leakage inspection

After the pipeline connection is done, use a leakage inspection device or soap suds to carefully check if there is any leakage at the joints. This is an important step to ensure the quality of installation. Once a leakage is detected, proper treatment should be taken immediately.

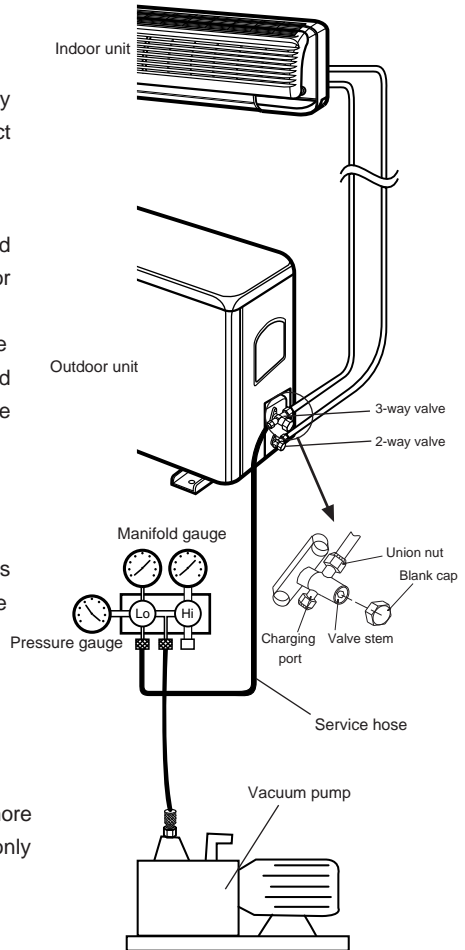

Fig. 8

* Connection of power cable*

- 1.Remove the drawer of the outdoor unit.
- 2.**Non-quick coupler:**connect the indoor power and control wires with the matched outdoor wires in accordance with the electric schematic diagram and make sure that the connection is firmly done(Fig.9).

Quick coupler:directly connect quick cable couplers with indoor and outdoor quick cable couplers after disassembly of the outdoor unit connecting box cover (Fig.10).

- 3.Use a press plate to fix the wires firmly,and re-install the drawer.

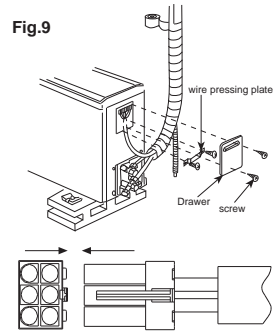

Fig.10

Note:Do not connect the wires in a wrong way,otherwise electric malfunctions will be caused and even damages to the units will occur.The appliance shall be installed in accordance with national wiring regulation.If the supply cord is damaged,it must be replaced by the manufacturer or its service agent or a similarly qualified person in order to avoid a hazard.The plug shall be accessible after installing the appliance.If the model have not plug that a switch which have a contact separation of at least 3 mm(1/10") in all poles shall be added in fixed wiring.

* Finishing touches *

- * Use thermal tube to wrap the joints and wrap the tube tightly with ethylene tapes.
- * Fix the wrapped pipelines on the exterior wall with clamps.
- * Fill in the gaps left over by the pipeline hole and wall hole to prevent rain-water from entering.

* Test running*

- * Connect to the power source,check if the function selection keys on the remote controller are working properly.
- * Check if the room temperature adjustments and timer settings are working properly.
- * Check if the drain is smooth.
- * Check if there is any abnormal noise or vibration during operation.
- * Check if there is leakage of refrigerant.

* Is the unit installed correctly? *

* Suitable Installation Position

*Isn't there anything which prevents ventilation or obstructs operation in front of the indoor unit ?
Do not install the unit following place .

*Inflammable gases may leak .

*Oil splashes a lot .

*In case where the unit is used in such places as poisonous or sultry gases are generated or seaside district exposed to sea breezes corrosion may cause malfunction . Consult with your distributor .

*Air conditioner body and remote controller must be 1 m(39-3/4") or more away from a TV or a radio.
Drain the dehumidified water from the indoor unit to a place which drains well .

* Pay attention to operation noise

*When installing the unit , choose a place which can stand the weight of the unit well and does not increase the operation noise or vibration . Especially where there is a possibility that vibration be transmitted to the house , fix the unit by inserting attached vibration -proof pads between the unit and fittings .

*Choose the place where hot air and operation noise from the outlet of the outdoor unit do not annoy the neighborhood .

*Things left near the outlet and inlet of the outdoor unit cause malfunction or increased operation noise . Do not leave obstacles near the outlet and inlet .

*If irregular sound is heard during operation , consult with your distributor .

*Inspection and Maintenance

*According to the service conditions and operating environment , the inside of the air conditioner will become dirty after several seasons (3 to 5years) of service , resulting in decreased operating performance .Inspection and maintenance are recommended in addition to usual cleaning (The air conditioner can be used for a longer period and without anxiety .)

*As to inspection and maintenance , consult your dealer or any one of business offices of dealing companies .(Service charge is required in this case .)

*We recommend to perform inspection and maintenance during an off seasons.

Self Diagnosis Functions

Our company provides the thoughtful services for customer,air conditioners had been installed self diagnosis system to display the information for the units.

<i>Self-check information</i>	<i>Self-check code of luminotron/ (Self-check code of running lamp)</i>	<i>Digital self-check code/ (Polychrome screen self-check code)</i>
Hint to defrosting	Flicker 1 time/1s	Indicates "dF"or defrosting indicator displays
Hint to defense against cold wind	Flicker 1 time/3s	Fan motor picture not running
Failure of room temperature sensor	Flicker 2 times/4s (Flicker 2 times/8s)	E2/(L2)
Failure of coiled pipe sensor	Flicker 3 times/5s (Flicker 1 time/8s)	E3/(L1)
Abnormality of outdoor unit	Flicker 4 times/6s (luminating)	E4/(E5)
Without feedback of internal fan motor	Flicker 5 times/7s (Flicker 6 times/8s)	E5/(L6)
Zero crossing signal without current	Flicker 6 times/8s	E6
External feedback failure	Flicker 7 times/9s	E7
Overheat protection	Flicker 8 times/10s	E8
Water pump failure	Flicker 9 times/11s	E9

Note:Above self check information is commonly applicable in our most air conditioners,but some are special,you can refer to the User's Manual for information or contact the dealer or authorized maintenance people for help.

9k&12k indoor wire diagram (cooling&heating)

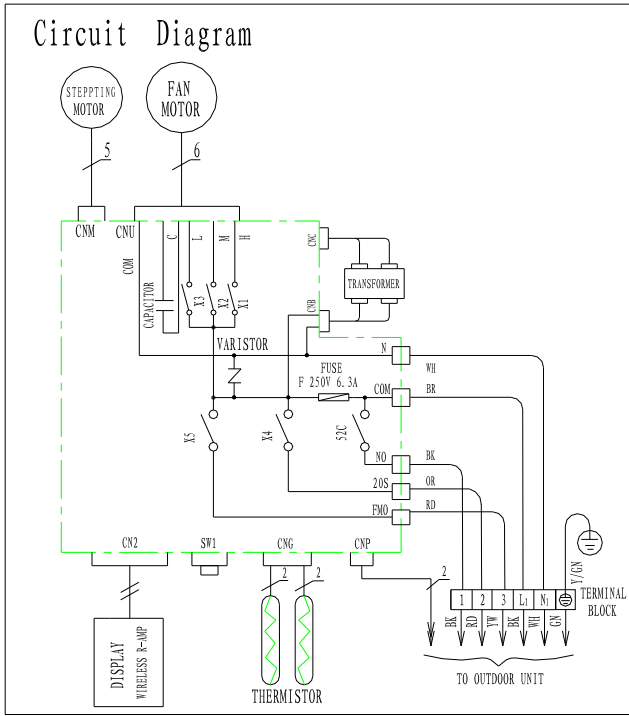

9k&12k outdoor wire diagram (cooling&heating)

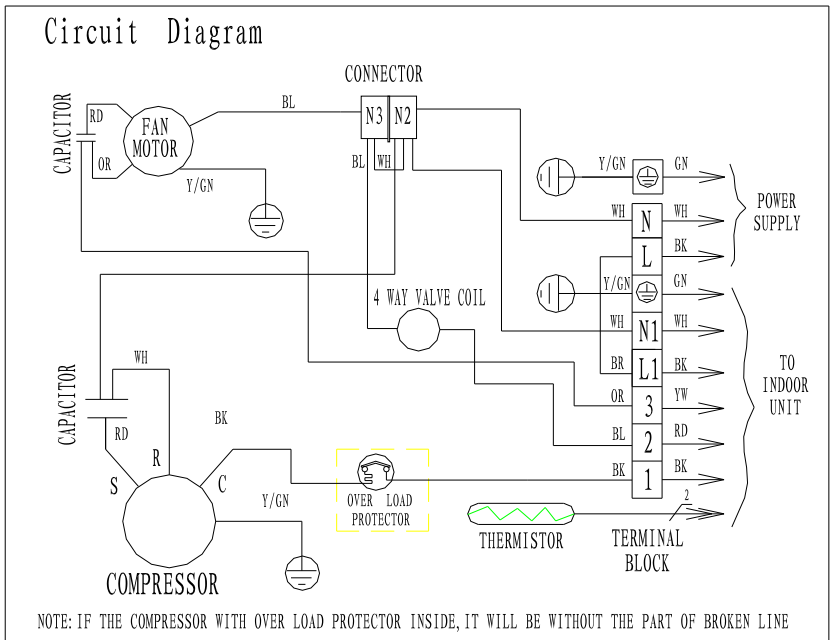

18k&24k indoor wire diagram (cooling&heating)

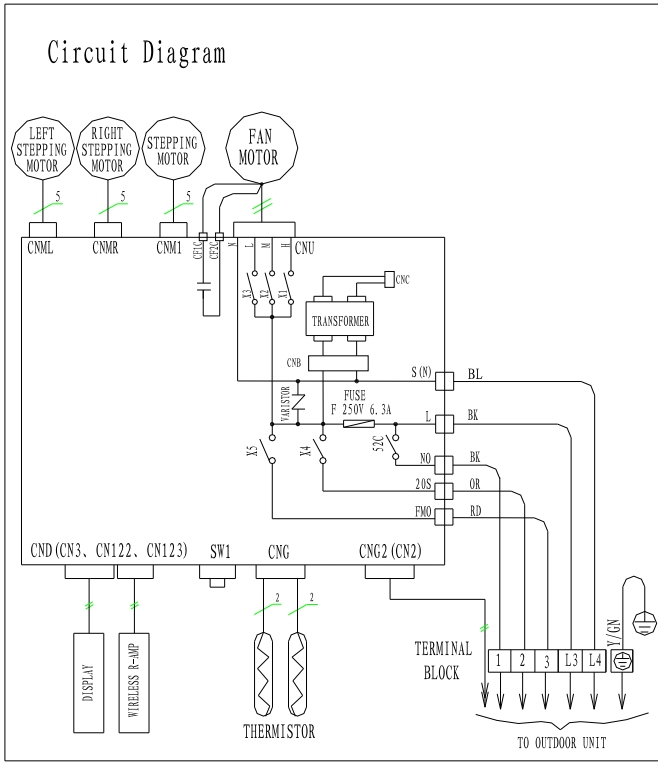

18k&24k outdoor wire diagram (cooling&heating)

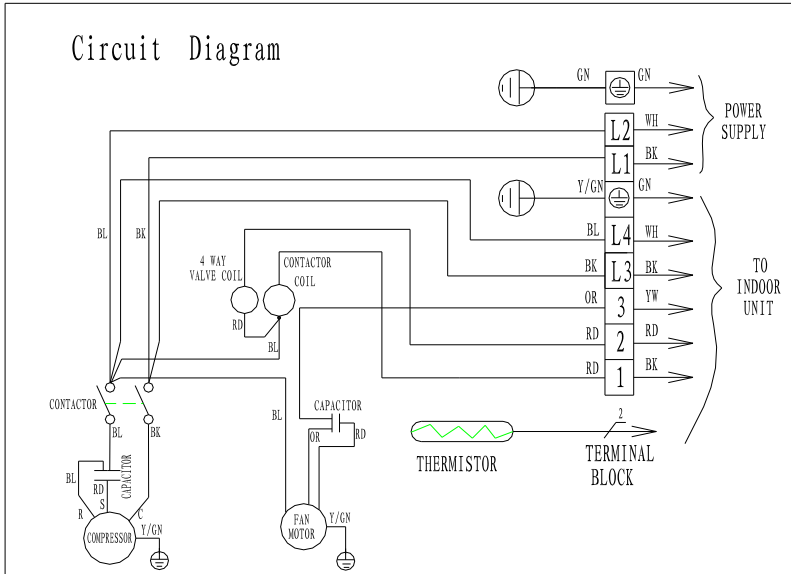

Hong Kong
Amcor Ltd
Suites 1010-1011, Ocean Centre,
Harbour City, 5 Canton Road,
Tsim Sha Tsui, Kowloon,
Hong Kong.
Tel: +852 2997 6865
Fax: +852 2997 6091
Email: amcorhk@amcorgroup.com

United Kingdom
Amcor Ltd
9 Ryan Drive, West Cross Centre,
Great West Road, Brentford,
Middlesex, TW8 9ER,
United Kingdom
Tel: +44 20 8560 4141
Fax: +44 20 8232 88141
Email: amcoruk@amcorgroup.com

USA
Amcor Inc.
685A Gotham Parkway, Carlstadt ,
New Jersey 07072,
United States of America
Tel: +1 201 460 8100
Fax: +1 201 460 9481
Email: amcorusa@amcorgroup.com

The Netherlands
Amcor B.V.
Anton Philipsweg 9-11,
1422 AL Uithoorn,
The Netherlands
Tel: +31 297 560 079
Fax: +31 297 523 062
Email: amcorex@amcorgroup.com

Israel
Amcor International Ltd
1 Sapir Street, Herzelia Pituach,
46733, Israel
Tel: +972 9 951 5351
Fax: +972 9 958 5650
Email: amcoril@amcorgroup.com

Singapore
Amcor Investments (Singapore) Pte Ltd
545 Orchard Road,
#13-02, Far East Shopping Centre,
Singapore 238882
Tel: +65 6297 9881
Fax: +65 6297 8891
Email: amcorsg@amcorgroup.com

Panamá office
Edif. Metrobank Piso 2, Punta Pacifica
Apdo. 0832-0226
Panamá, Rep. De Panamá
Tel: (507) 215 4000
Fax: (507) 215 3874
E-mail: 0had.Forstner@amcorgroupla.com

Colombian office
Carrera 9 No. 74-08, of. 1006
Bogotá-Colombia
Tel: (571) 347 1055
Fax: (571) 345 3828
E-mail: Sergio.Velez@amcorgroupla.com

China
Shan Xia Industrial Development Zone,
Heng Li Town, Dongguan City,
Guangdong Province, China

Plant One - Amcor (China) Ltd
Tel: +86 769 8372 1090
Fax: +86 769 8372 1790
Email: amcoren@amcorgroup.com

Plant Two - Amcor Appliances Ltd
Tel: +86 769 8372 1970
Fax: +86 769 8372 1790
Email: amcorappl@amcorgroup.com



VERIFIED



VERIFIÉ
233041

Energy
Performance
Rendement
Énergétique
SEER 13



SA 12793